NSC
HEAT SEAL MANUAL

MACHINE NAME RESISTAG III & III-A
MODEL NUMBER HS173 AND HS179



Innovators of the Future

Natmar Services Company

139 Beattie Street • P.O.Box 6743 • Syracuse, NY 13217

Toll Free 800-798-8206 • Local (315) 445-2419 • Fax (315) 445-8046

Visit us on the web at www.natmar-nsc.com

Section 1	1-4
DESCRIPTION OF THE MODEL HS173 & HS179, RESISTAG III & III-A HEAT SEAL MACHINES.....	1-4
MACHINE SPECIFICATIONS	1-4
SETTING UP	1-4
SAFETY INFORMATION	1-5
Section 2	2-1
CONTROL PANEL INSTRUCTIONS	2-1
OPERATING INSTRUCTIONS	2-2
HEAT SEALING GUIDE	2-3
Section 3	3-1
ADJUSTMENTS	3-1
Section 4	4-1
PROBLEM ANALYSIS AND SOLUTIONS	4-1
ERROR CODES	4-2
Section 5	5-1
MAINTENANCE.....	5-1
Section 6	6-1
PARTS IDENTIFICATION AND LOCATION	6-1
MACHINE COVERS AND MOTOR IDENTIFICATION	6-3
WIRING DIAGRAM AND ELECTRICAL PARTS	6-4



Natmar Services Company

139 Beattie Street • P.O. Box 6743 • Syracuse, NY 13217

Toll Free 800-798-8206 • Local (315) 445-2419 • Fax (315) 445-8046

Warranty For Heat Seal Machine

Natmar Services Company, Syracuse, New York ("Seller") warrants this Heat Seal machine to be free from defects in material and workmanship under normal use and service. Any part which proves to be defective in material or workmanship within one year of the date of original purchase for use, will be repaired or replaced, at Seller's option, free of service or labor charges, with a new or functionally operative part. Seller's liability under the Warranty shall be limited to repairing or replacing at its own factory or through an authorized service distributor or dealer, material which is determined by Seller to have been defective in manufacture and upon which a claim has been made by the original purchaser or user to Seller (or an authorized distributor or dealer) within the warranty period. An authorized officer of Seller will honor claims under this Warranty only upon written approval. Approved return of parts or products will be on a prepaid transportation charges basis only. Claims under this Warranty will be honored only upon Seller's determination that the claim is covered by this Warranty, and Seller shall incur no obligation under this Warranty prior to such determination. This Warranty does not apply: (1) To any machinery or equipment which has been altered or repaired, except by Seller or its authorized representatives, or (2) to any machinery or equipment which has been subject to misuse, negligence, or accident, including, without limitation, use an operation of such machinery or equipment while parts are loose, broken, out of order, or damaged by the elements. Parts replaced under this Warranty are warranted only through the remainder of the original Warranty. Any and all claims for warranty service must include such information as Seller designates, and shall include specifically the serial number of each unit (if appropriate).

The foregoing shall constitute the sole and exclusive remedy of any using purchaser and the sole an exclusive liability of Seller in connection with this product. THIS WARRANTY IS IN LIEU OF ALL OTHER WARRANTIES, EXPRESS, IMPLIED OR STATUTORY, INCLUDING BUT NOT LIMITED TO, ANY WARRANTY OF MERCHANTABILITY OR FITNESS AND ALL OTHER OBLIGATIONS OR LIABILITIES OF SELLER, INCLUDING ANY TORT LIABILITY, FOR NEGLIGENT DESIGN OR MANUFACTURE OF THIS PRODUCT, OR OTHERWISE. It is expressly agreed that Buyer shall not be entitled to recover any incidental or consequential damages, as those terms are defined in the Uniform Commercial Code, and that Buyer shall have no right of rejection or of revocation of acceptance of any part or of revocation of acceptance if any part or all of the goods covered hereby.

Natmar Services Company reserves the right to make changes in design and changes or improvements upon its product without imposing any obligation upon itself to install the same upon its products previously manufactured.

Section 1

DESCRIPTION OF THE RESISTAG III & III-A HEAT SEAL MACHINES

These manually actuated heat-seal machines provide the heat, time and pressure required for the application of a wide range and variety of Natmar products including mending materials, emblems, label tapes, and transfers.

The handle of the Model HS173, RESISTAG III Heat Seal Machine is manually lowered to its locked position and manually raised at the completion of the variable time cycle, which is signaled by a buzzer.

The handle of the MODEL HS179, RESISTAG III-A Heat Seal Machine is manually lowered to its locked position and automatically released and raised at the end of the time cycle.

Both models have the energy saving feature “power saver”. If the machine is turned on but not being used, the heater will be turned off after a preset time. The next time it is used the heater will increase to the preset temperature, the buzzer will sound or it will release automatically.

MACHINE SPECIFICATIONS

Width	7.5"	(19 cm)
Length	20.4"	(52 cm)
Height (Opened):	19.3"	(49 cm)
(Closed):	9.3"	(24 cm)
Sealing Platen:	3.75" x 4.75"	(9.5 cm x 12 cm)
Time:	0 to 30 seconds	
Heat Range:	69 to 446°F	(20 to 230°C)
Electrical Requirements:	5.6 Amps @ 110 VAC, 50/60 HZ or 2.8 Amps @ 220 VAC, 50/60 HZ	

SETTING UP

1. Set the machine on the worktable in a desired location.
2. Plug the electrical power cord into the socket at the back of the machine.
3. Plug the electrical power cord into a properly grounded outlet of the correct voltage.

SAFETY INFORMATION

This machine is equipped with a fully grounded 3-wire cord and plug. It must be used only in conjunction with a properly grounded outlet of the correct voltage.

WARNING: THE HEATING IRON CAN CAUSE SKIN BURNS!

Section 2

CONTROL PANEL INSTRUCTIONS

Normal Operations:

Turn machine on. Either the Celsius or Fahrenheit LED will blink depending on what it is set to. The actual temperature is displayed.

Because of the power saver if you try to activate the machine before it is up to temperature, it will continue to increase temperature until the set temperature is reached and the buzzer will sound, (RESISTAG III) or it will release automatically (RESISTAG III-A).

During the heat up, and also when the machine reaches set temperature, it is possible to change the machine settings for temperature, time and between °C and °F and power saver time and temperature. See procedure below to make these changes.

The Celsius or Fahrenheit LED will light up continuously once the temperature is within range of the setting. Range is +/- 7°C or +/-15°F.

When not in a sealing cycle, the actual temperature is displayed.

During a sealing cycle, the display will show a countdown of the time.

It is not possible to change settings during a sealing cycle.

Procedure to change desired temperature:

Factory set at 400°F (204°C).

1. Press select/save button.
2. Press + or - button to set the desired temperature.
3. Press select/save to save the setting.

Note: If the save button is not touched within 3 seconds after making a change, the display will change to the actual temperature and no changes will be made or saved.

Procedure to change desired time:

Factory set at 12 seconds.

1. Press the select/save button twice.
2. Press + or - button to set the desired time.
3. Press select/save to save the setting.

Note: If the save button is not touched within 3 seconds after making a change, the display will change to the actual temperature and no changes will be made or saved.

Procedure to change between °C and °F:

Press the + and - buttons and hold for more than 3 seconds and the LED and setting will change.

Procedure to change power saver time:

Factory set at 5 minutes.

1. Press select/save button three times.
2. Press + or - button to set time (0 to 60 minutes) before “off”.
3. Press select/save to save the setting.

Procedure to change power saver temperature:

Factory set at 338°F (170°C).

1. Press select/save button four times.
2. Press + or - button to set temperature.
3. Press select/save to save the setting.

OPERATING INSTRUCTIONS

Important: Read this entire section before operating machine.

1. Raise handle to its full upright position.
2. Push power switch at rear of machine to “on” position. The Celsius or Fahrenheit light on the front panel will blink indicating that power is being supplied and that the sealing iron is not at the proper temperature.

When the sealing iron has reached operating temperature, the light on the front panel will not blink. See page 2-1 for time, temperature and power/saver adjustments. The temperature cannot be set higher than 446°F (230°C). Always check control panel display prior to operating the press.

WARNING: THE HEATING IRON CAN CAUSE SKIN BURNS.

See Section 3 if pressure adjustment is necessary. Generally speaking, higher pressures will produce more effective heat sealing, while excess pressure may force adhesive through the fabric, with an unsightly result.

3. With heat, time and pressure at recommended levels, center the work on the pad.
4. Place the repair patch, emblem or label tape adhesive shiny side down. (Transfers should be placed ink side down).
5. Lower the handle to its locked position.
6. When the buzzer sounds, raise the handle to its upright position (RESISTAG III).

The RESISTAG III-A will automatically release and return to the upright position at the completion of the time cycle. If the handle on an RESISTAG III-A does not return automatically a buzzer will sound and it can be opened manually by lifting handle.

CAUTION: FOR BEST RESULTS, SEALED MATERIAL SHOULD BE HANDLED CAREFULLY UNTIL IT HAS COOLED TO ROOM TEMPERATURE.

HEAT SEALING GUIDE

	PRESSURE SETTING*	TIME CYCLE**
Thermo Crest Emblems	High (8 to 9)	12 seconds
Mending Materials	Medium (7 to 8)	10 seconds
Identification Tapes	Medium (6 to 7)	10 seconds
Thermomark Transfers	Low (4 to 6)	4 - 6 seconds
Polystat Transfers	Low (4 to 6)	24 seconds

* See Section 3-1

** See Section 2-1

Section 3

ADJUSTMENTS

Temperature - See page 2-1

Time - See page 2-1

Power Saver - see Page 2-1

The machine has been factory preset to:

TEMPERATURE - 400°F (204°C).

TIME - 12 seconds

POWER SAVER - Heater off after 5 minutes

- Release or buzzer at 338°F (170°C)

Sealing Pressure

Referring to the label in front of the platen, turn the lower platen base counterclockwise to increase the pressure or clockwise to decrease. The Pressure Setting numbers in the Heat Sealing guide on page 2-3 are used as follows. Turn the base clockwise until it bottoms out against the base, and then turn counterclockwise slightly until the first “click”. This is the number zero. Now, turn the platen base counterclockwise, counting the number of “clicks” which is the pressure setting number. Let’s say you are using the machine and want to know the pressure setting you are using so you can write it down for future reference. Turn the platen base clockwise, counting the number of “clicks” until the base reaches bottom. The number of clicks is the pressure setting. To get this same setting in the future, bottom out the base as described above and count the same number of clicks while turning the base counterclockwise.

Settings may vary depending upon how thick the garment is. Generally speaking, higher pressures will produce more effective heat sealing, while excess pressure may force adhesive through the fabric, with an unsightly result.

The RESISTAG III-A will not open under excess pressure. If it is hard to close, more than 22 lbs. (100 N), at handle, it will not open automatically. To prevent excess pressure when sealing thick garments, screw the platen all the way down.

Insufficient pressure can be caused by a platen that is worn or taken a set with age or use. Replacement (43941) is recommended.

Section 4

PROBLEM ANALYSIS AND SOLUTIONS

PROBLEM	POSSIBLE CAUSE	SOLUTION
No heat.	<ul style="list-style-type: none"> - Machine is unplugged or power source is faulty. - Main power switch is not "ON". - Temperature displayed. - Loose wires. - Heat sensor is defective. - Sealing iron is defective. - Relay is defective. - Heat controller is defective. 	<ul style="list-style-type: none"> - Check plug and fuses. - Check - See Section 2 - Check - Replace - Replace - Replace - Return circuit board to factory for repair.
Temperature too high or too low.	<ul style="list-style-type: none"> - Heat control requires adjustment. - Temperature display is incorrect. - Heat sensor is defective. - Sealing iron defective. - Heat controller is defective. 	<ul style="list-style-type: none"> - See Section 2 to adjust. - See Section 2 to check. - Replace - Replace - Return circuit board to factory for repairs.
Time malfunction.	<ul style="list-style-type: none"> - Loose wires. - Timer is defective - Micro switch is defective. 	<ul style="list-style-type: none"> - Check - Return circuit board to factory for repairs. - Replace.
Handle does not stay down. Handle does not return at end of cycle (RESISTAG III-A).	<ul style="list-style-type: none"> - Insufficient pressure. - Excess pressure. - Motor is defective. - Linkage or gas spring is binding. - Springs are weak. 	<ul style="list-style-type: none"> - See page 3-1. - See page 3-1. - Replace - Lubricate or adjust. See page 5-1 and 6-1 Note 1. - Replace
Inadequate bond or transfer.	<ul style="list-style-type: none"> - Insufficient sealing time. - Insufficient pressure. - Insufficient temperature. - Pad worn. - Teflon shield soiled or worn. 	<ul style="list-style-type: none"> - Increase time in 2 second increments and test. - Increase pressure in one half turn increments and test. - See Section 2 to adjust. - Replace - Clean or replace.
Bleed through.	<ul style="list-style-type: none"> - Too much time. - Too much pressure. 	<ul style="list-style-type: none"> - Decrease time in 2 second increments. - Decrease pressure in one half turn increments.

ERROR CODES

Error 1 = Temperature sensor short (0 Ohm)

Error 2 = Temperature sensor broken.

Error 3 = Error in E-prom

The processor has no access to the memory for saving or reading of information.

Error 4 (RESISTAG III-A only) = Motor timed out, not in position or motor switch error.

There's something wrong with the motor-position-detection. When motor rotates,
Check switch and or switch wires.

Section 5

MAINTENANCE

Teflon Cover - Clean often by wiping with a soft clean rag. A non-flammable cleaner such as “EZ-Off”, part number DH-6873, may be used according to the manufacturer’s instructions. Never use a flammable solvent or abrasive cleaner. To ensure the best heat-sealing results, regularly replace the cover whenever it becomes torn or too soiled to clean.

To replace the cover:

1. Gently peel the Teflon cover from the sealing iron. It may be necessary to use a thin object, such as a screwdriver or knife, to begin the peeling process. Be careful not to damage the surface of the sealing iron.
2. Clear foreign debris from the sealing iron before applying a new Teflon cover.
3. Apply new Teflon cover by removing backing and sticking to sealing iron making sure to cover entire surface.
4. Trim any excess off the new cover, while being careful not to damage the sealing iron surface.

Trimming the excess is important. Failure to do so may result in the Teflon cover peeling off the sealing iron while heated.

Platen Assembly - Clean often by wiping with a soft, clean rag. Replace the pad whenever it becomes deteriorated.

To replace platen assembly:

From the side, gently wedge a screwdriver between aluminum base and aluminum backing plate of the platen assembly. It can now be pulled from the base.

Lubrication - No lubrication is necessary since permanently lubricated bearings are used in this machine, however, oiling all pivot points and rotating parts will help, if handle is slow to return.

Section 6

PARTS IDENTIFICATION AND LOCATION

NOTES:

1. MOUNT GAS SPRING WITH ROD DOWN AT BASE.
DO NOT NICK OR SCRATCH EXPOSED ROD DURING
ASSY. MOUNT BRK'T TO UPPER END OF GAS SPRING
BEFORE MOUNTING IN MACHINE. LOWER END WITH
BALL JOINT TO BE MOUNTED TO BASE FIRST.
2. PART NUMBER SHOWN IN PARTS LIST IS FOR 110V MACHINE.
FOR A 220V MACHINE USE THE FOLLOWING PARTS.
ITEM 36 46396 HEATER ASSY - CERAMIC 220V

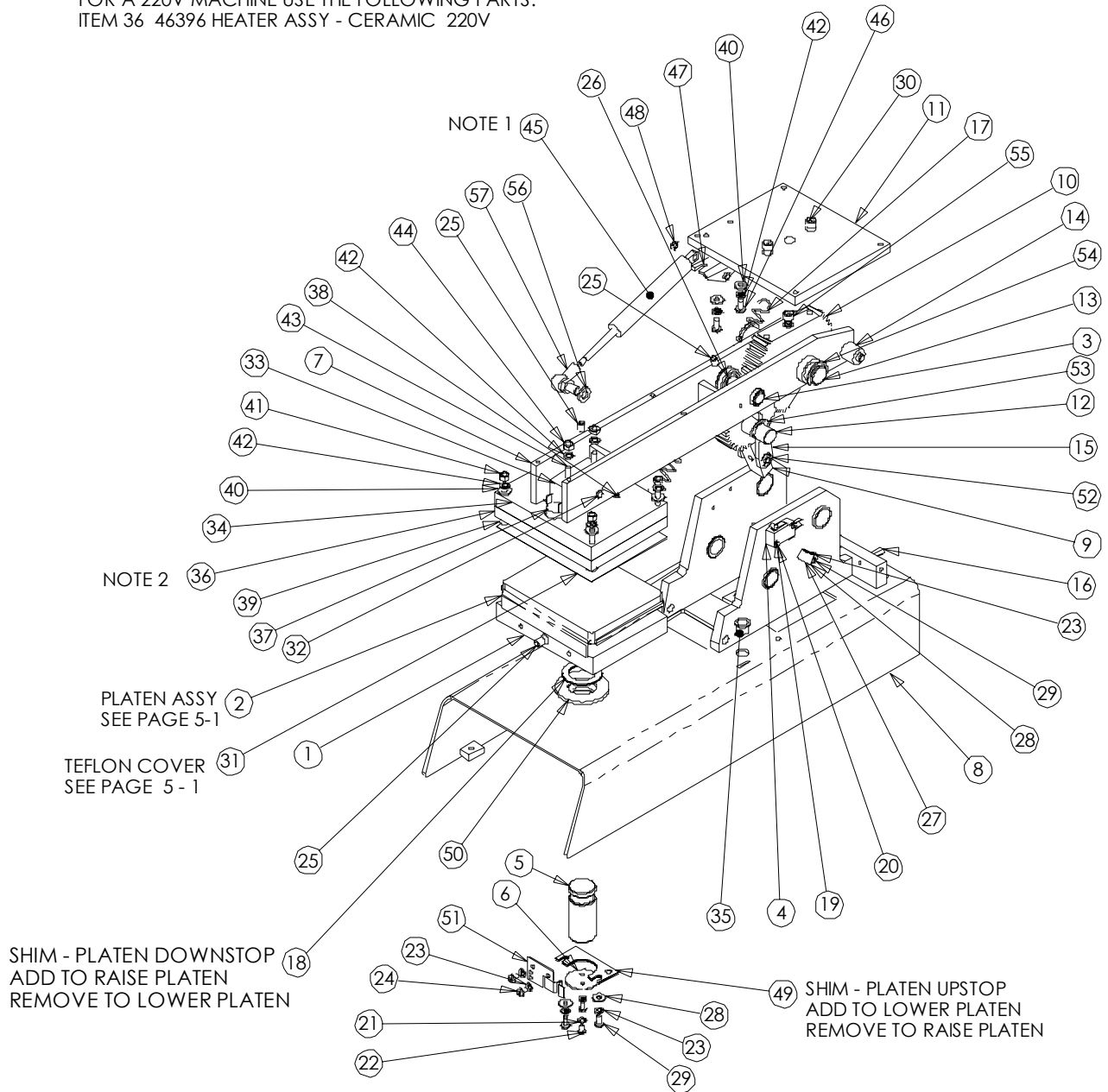

[Table of Contents](#)

ITEM NO.	QTY.	PART NO.	DESCRIPTION	ITEM NO.	QTY.	PART NO.	DESCRIPTION
1	1	43663	BASE - PLATEN	30	2	21063-05-K	SHCS 1/4 - 20 X 3/4 LG
2	1	43941	PLATEN ASSY	31	1	46375	TEFLON COVER
3	1	46328	SHAFT - LINK PIVOT	32	1	46379	PIN - BLOCK
4	1	20055-62	SWITCH - MICRO	33	1	46378	BLOCK - HTR MTG
5	1	46320	THD ROD - PLATEN ADJ	34	1	46377	PLATE - HEATER INSULATING
6	1	43644	STOP WASHER	35	1	ST-1062	GROMMET - PLASTIC
7	1	46314	ARM ASSY - SEALING	36	1	46395	HEATER ASSY - CERAMIC 110V
8	1	46301	BASE ASSY - WELDMENT	37	1	20018-24	THERMOSTAT- HI LIMIT
9	1	46493	GEAR ASSY - 24T	38	2	24075-36	SPRING - COMPRESSION
10	1	46325	GEAR - 48T MACHINED	39	4	21044-12-C	FHS M5 X 40mm LG SLOT
11	1	46312	PLATE - COVER	40	6	21023-01	F'W - #10
12	1	46492	SHAFT - 24T GEAR PIVOT	41	4	21045-07-A	NUT - M5
13	1	46330	SHAFT - 48T GEAR PIVOT	42	8	21021-07-A	L'W - INT NO. 10
14	2	24091-44	BUSHING - RUBBER	43	2	21056-15-H	FHS 10-32 X 2.0 LG
15	2	46307	LINK - CLAMP	44	2	21051-09-A	NUT - #10-32
16	2	21028-47	STANDOFF - 1/4 HEX - 8-32 M/F	45	1	24091-48	GAS SPRING
17	1	24080-35	SPRING - EXT LE-075E-12 ARM	46	2	21058-05-H	PHS 10-32 X 3/8 LG
18	2	43895	WASHER - FLAT 1.0 ID X 1/32 TK	47	1	46374	BRKT ASSY - GAS SPRING
19	2	21021-03-A	L'W - INT NO 4	48	1	D-9706	E-RING X5133-21
20	2	21058-07-C	PHS 4-40 X 1/2 LG	49	3	46382	SHIM - PLATEN UPSTOP
21	2	21021-05-A	L'W - INT NO. 6	50	1	21023-11	WASHER - FLAT 1.0 ID X 1/8 TK
22	2	21058-03-E	PHS 6 - 32 X 1/4 LG	51	1	43656	SPRING ASSY - DETENT
23	5	21021-06-A	L'W - INT NO. 8	52	2	D-9702	E-RING 1/4 5133-25
24	2	21058-03-F	PHS 8 - 32 X 1/4 LG	53	2	21025-28	RETAINING RING 5/8 5133-62
25	3	21011-07-L	SET SCW - CUP 1/4-20 X 3/8 LG	54	2	21025-31	RETAINING RING 3/4 5133-75
26	2	21025-26	E-RING 1000-50 OR 5133-50	55	1	21063-09-K	SHCS 1/4-20 X 1 1/4 LG
27	1	D-1454	CLAMP - 3/8 CABLE	56	1	21021-10-C	L'W #5/16 SPLIT
28	3	21023-23	WASHER - FLAT NO. 8	57	1	24091-77	ROD END BALL JOINT WX22 M8
29	3	21058-05-F	PHS 8-32 X 3/8 LG				

MACHINE COVERS AND MOTOR IDENTIFICATION

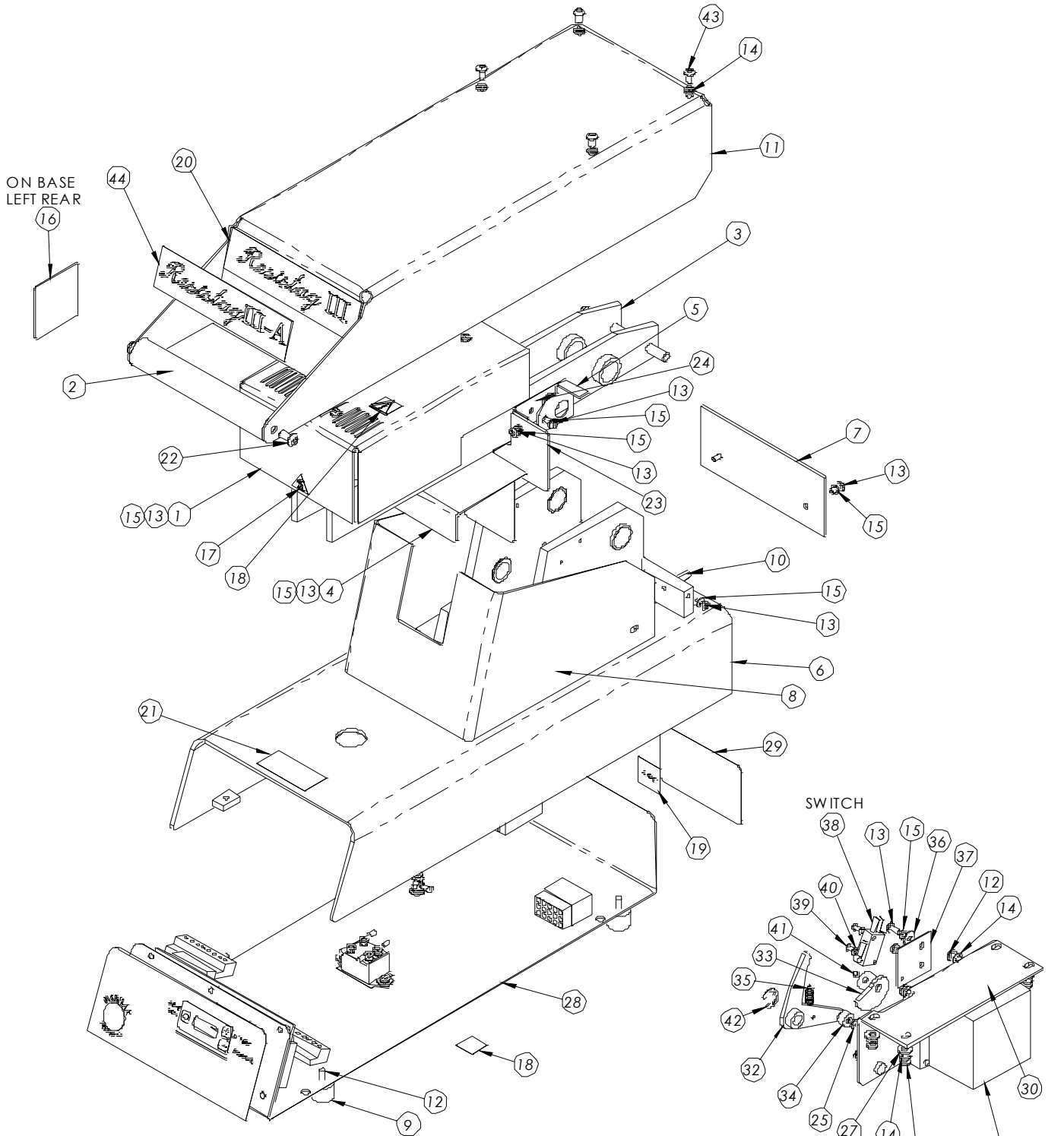

- NOTES:
1. PART NUMBER SHOWN IN PARTS LIST IS FOR 110V MACHINE. FOR A 220V MACHINE, USE THE FOLLOWING PARTS.
ITEM 32 - 46398 MOTOR ASSY, 220V.
ITEM 19 - 46413 3.15 AMP FUSE LABEL.

2. MOTOR BRKT - ASSEMBLY ALL PARTS BEFORE INSTALLING IN MACHINE. MAKE SURE SWITCH MAKES CONTACT, WHEN CAM IS ON THE HIGH POINT, UNDER THE SWITCH. PLATEN MUST BE SCREWED ALL THE WAY DOWN BEFORE INSTALLING MOTOR AND BRKT. WITH MACHINE UPSIDE DOWN ADJUST MOTOR BRKT SO THAT CAM ARM OUTPUT IS TOUCHING GEAR ARM WHEN CAM ROLLER IS AT LOW POINT ON CAM.

SEE NOTE 2 26

MOTOR ASSY
SEE NOTE 1

ITEM NO.	PART NUMBER	DESCRIPTION	QTY.
1	46309	COVER - IRON	1
2	46331	GRIP - HAND	1
3	46314	ARM ASSY - SEALING	1
4	46308	COVER - ARM	1
5	46334	ACTUATOR - SWITCH	1
6	46301	BASE ASSY - WELDMENT	1
7	46339	PLATE - REAR	1
8	46337	COVER ASSY - REAR	1
9	24090-79	RUBBER FOOT	4
10	21028-47	STANDOFF - 1/4 HEX - 8-32 M/F	2
11	46300	COVER - TOP	1
12	21058-09-H	PHS 10-32 X 3/4 LG	8
13	21058-05-F	PHS 8-32 X 3/8 LG	18
14	21021-07-A	L'W - INT NO. 10	12
15	21021-06-A	L'W - INT NO. 8	18
16	44771	LABEL - MADE IN USA	1
17	45425	LABEL, HOT SURFACE	1
18	45426	LABEL, HIGH VOLTAGE	2
19	46412	LABEL, FUSE WARNING, 6 AMP	1
20	70179	LABEL, RESISTAG III	1
21	46376	LABEL - PLATEN PRESSURE	1
22	21061-03-F	BUTTON HD SCR 1/4 - 20 X 1/2 LG	2
23	46363	COVER - CLOSEOUT	1
24	46364	BRK'T - CLOSEOUT COVER	2
25	D-9708	E - RING X5133-18	1
26	21058-05-H	PHS 10-32 X 3/8 LG	4
27	21023-01	F'W - #10	4
28	COVER ASSY - BOT'M	SEE PAGE 6-5	1
29	21977	LABEL, MODEL AND SERIAL NO.	1
30	70178	LABEL, RESISTAG III CONTROL	1
31	46399	BRKT ASSY - MOTOR	1
32	46397	MOTOR ASSY - 110V	1
33	46402	ARM ASSY - CAM	1
34	46408	CAM ASSY - RELEASE	1
35	46407	ROLLER - CAM	1
36	24080-29	SPRING - EXT LE0E26B00	1
37	21023-23	WASHER - FLAT NO. 8	2
38	46406	PLATE - SWITCH	1
39	20055-62	SWITCH - MICRO	1
40	21058-07-C	PHS 4-40 X 1/2 LG	2
41	21021-03-A	L'W - INT NO 4	2
42	21011-04-K	SET SCREW 10-32 X 3/16 LG	1
43	D-9705	E-RING 5133-37	1
44	21061-02-E	BHSCS 10-32 X 3/8 LG STN STL	4
45	70180	LABEL, RESISTAG III-A	1

SEE NOTE 1

RESISTAG III-A ONLY

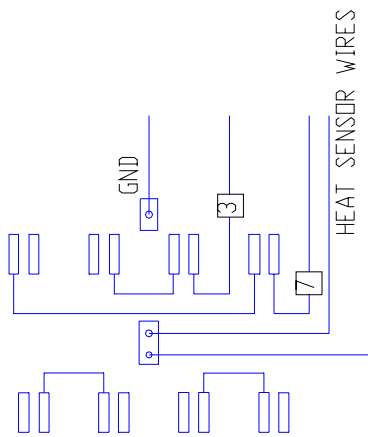

SCHEMATIC FOR
220V HEATER WIRING

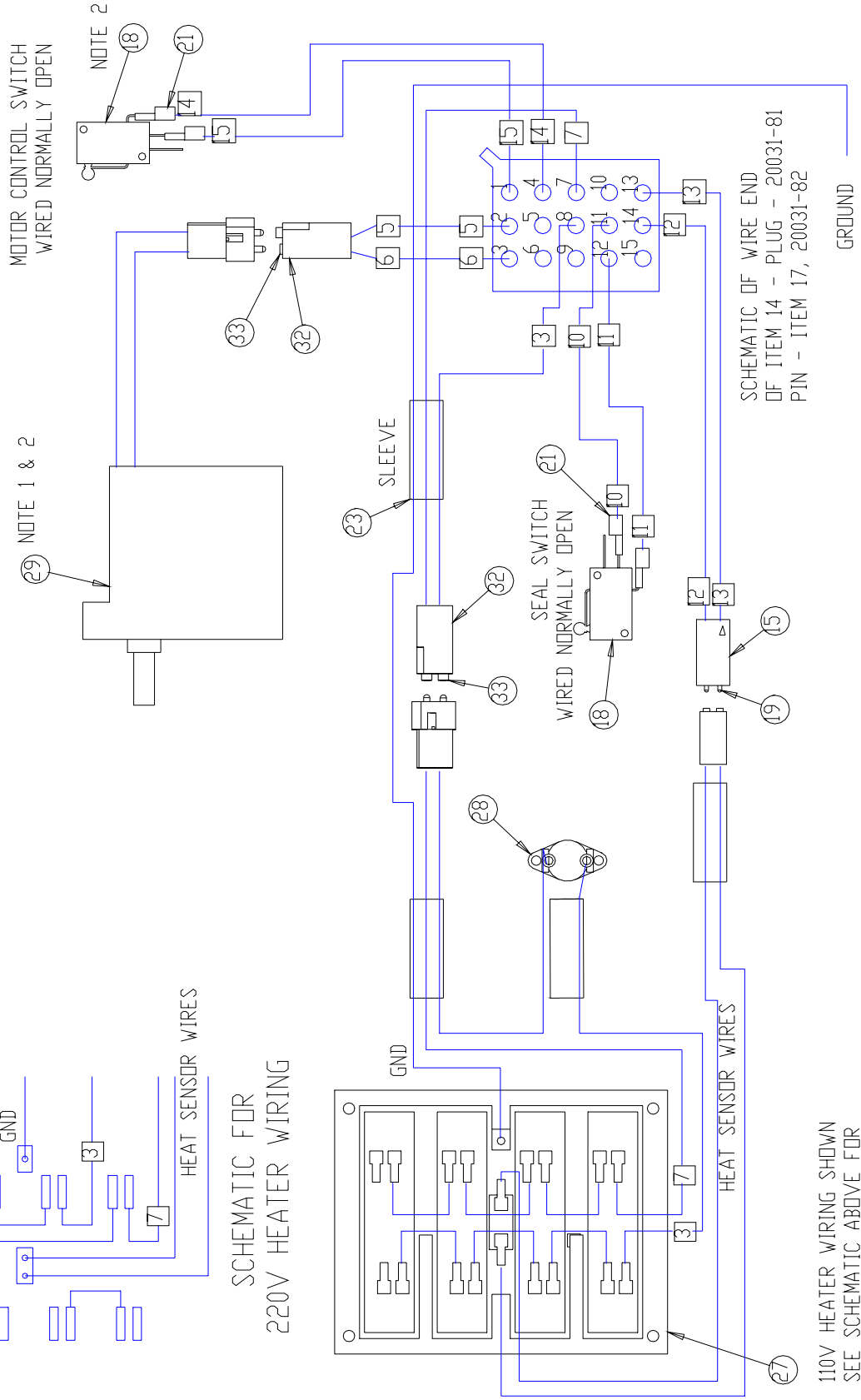

110V HEATER WIRING SHOWN
SEE SCHEMATIC ABOVE FOR
220V HEATER WIRING

[Table of Contents](#)

ITEM NO.	QTY.	PART NO.	DESCRIPTION
1	1	46326	COVER ASSY - BOTTOM
2	5	21021-06-B	L'W - EXT NO. 8
3	4	20003-19	RING TERM. - NO. 10 HI-TEMP
4	3	21051-07-A	HEX NUT - NO. 8-32
5	3	21058-03-C	PHS NO. 4-40 X .25 LG
6	3	21021-03-A	L'W - INT NO 4
7	2	21021-06-A	L'W - INT NO. 8
8	2	45413	LABEL - GROUND SYMBOL
9	1	20031-80	CAP - HOUSING 15 POS
10	10	20031-83	SOCKET
11	2	CONN-8 POS	
12	6	D-3127	RING TERM NO 6
13	3	PM-1422	CONN - 1/4 FEMALE FULL. INS
14	1	20031-81	PLUG - HOUSING 15 POS
15	1	20031-91	CONN - 2 PIN MALE
16	1	20031-92	CONN - 2 PIN FEMALE
17	10	20031-82	PIN
18	2	20055-62	SWITCH - MICRO
19	2	20030-102	PIN
20	2	20030-104	SOCKET
21	4	20003-35	CONN - 3/16 FEMALE FULL INS
22	2	20003-20	CONN - 1/4 FEMALE HI-TEMP
23	3	DH-6634	SLEEVE - 7/32 I.D.
24	1	20080-05	SLEEVE - 1/16 I.D.
NOTE 1	25	20015-20	FUSE - 6 AMP
NOTE 1	26	20080-70	CORD - LINE 110V IEC CONN
NOTE 1	27	46395	HEATER ASSY - CERAMIC 110V
	28	20018-24	THERMOSTAT- HI LIMIT
NOTE 1 & 2	29	46397	MOTOR ASSY - 120V
	30	20030-12	PLUG - 2 POS FEMALE
	31	20030-03	PIN
	32	20030-11	RECEPTACLE - MALE
	33	20030-04	SOCKET
	34	21058-04-F	PHS 8-32 X .31 LG
NOT SHOWN	35	40382	LABEL - LINE CORD
NOTE 3	36	46411	CIRCUIT BOARD ASSY
	37	20040-54	RELAY - SOLID STATE
	38	21023-23	WASHER - FLAT NO. 8
	39	20000-78	CAPACITOR - 220pF
	40	46453	POWER ENTRY MODULE ASSY

NOTES

1. PART NUMBER SHOWN IN PARTS LIST IS FOR 110V MACHINE
FOR A 220V MACHINE USE THE FOLLOWING PARTS.
ITEM 25 - 20015-26 3.15 AMP FUSE
ITEM 26 - 41969 - LINE CORD 220V NOT SHOWN IN DWG
ITEM 27 46396 HEATER ASSY 220V
ITEM 29 46398 MOTOR ASSY 240V
2. MOTOR ASSY AND ASSOC. CONN, PINS AND WIRING NO'S 5 AND 6;
MOTOR CONTROL SWITCH AND ASSOC. CONN, PINS AND WIRING NO'S 14 AND 15,
USED ON RESISTAG III-A ONLY, NOT REQ'D ON RESISTAG III.
3. ITEM 36 - CIRCUIT BOARD ASSY - ON RESISTAG III, USE 46435 IF 46411 IS
NOT AVAILABLE